

# Signal Wafer Butterfly Valve PN16

## FIG. BL 104 SN

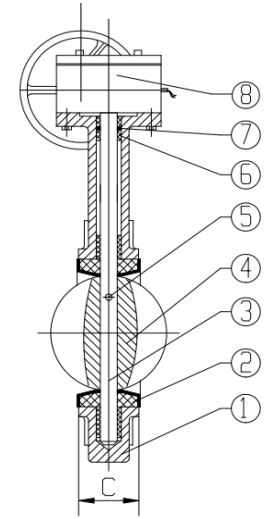
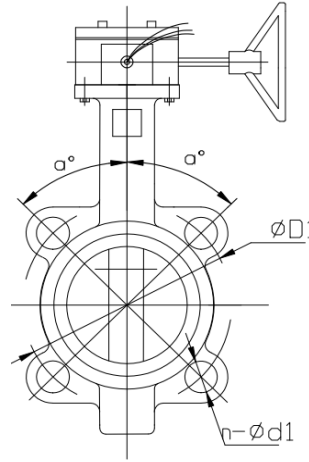

### TECHNICAL DATA

WORKING PRESSURE	16bar	
TESTING PRESSURE	SHELL TEST	24bar
	SEALING TEST	17.6bar

### DIMENSIONS

In	DN	C	D1	n-Ød	a
2	50	42	125	4-19	45
2 1/2	65	45	145	4-19	45
3	80	44.2	160	4-19	22.5
4	100	51.1	180	4-19	22.5
5	125	54.5	210	4-19	22.5
6	150	54.8	240	4-23	22.5
8	200	59.6	295	4-23	15
10	250	67	355	4-28	15
12	300	75.9	410	4-28	15

### MATERIALS OF MAIN PARTS

	PARTS	MATERIALS	REMARK
1	Body	Cast Iron	
2	Seat	EPDM	
3	Shaft	SS ANSI 410	
4	Disc	Ductile Iron	
5	Pin	Stainless Steel 410	
6	Bushing	Polymers	
7	O ring	EPDM	
8	Gear Operator		Signal