

OS&Y Resilient Seat Gate Valve (BS5163 PN16) FIG. OSY-200

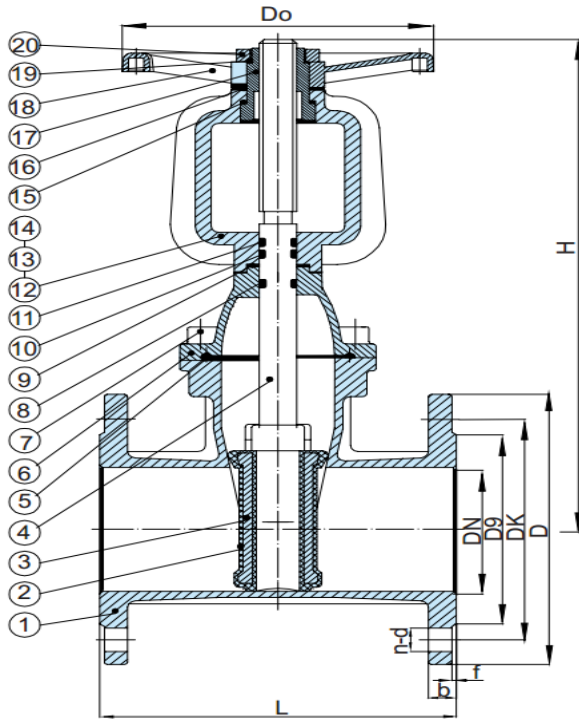

| | |
|-----------------|-----------------|
| CONFORMS TO | BS5163 & BS5150 |
| DESIGN STANDARD | BS5163 |
| FACE TO FACE | BS5163 |
| FLANGES | BS4504 & EN1092 |

TECHNICAL DATA

| | | |
|------------------|------------|-------|
| WORKING PRESSURE | 16bar | |
| TESTING PRESSURE | SHELL TEST | 24bar |
| | SEAT TEST | 16bar |

| DN | L | Dg | DK | D | n-d | Do | H |
|-----|-----|-----|-----|-----|-------|-----|------|
| 50 | 178 | 99 | 125 | 165 | 4-19 | 160 | 410 |
| 65 | 190 | 118 | 145 | 185 | 4-19 | 200 | 487 |
| 80 | 203 | 132 | 160 | 200 | 8-19 | 200 | 538 |
| 100 | 229 | 156 | 180 | 220 | 8-19 | 200 | 620 |
| 125 | 254 | 184 | 210 | 250 | 8-19 | 250 | 673 |
| 150 | 267 | 211 | 240 | 285 | 8-23 | 250 | 726 |
| 200 | 292 | 265 | 295 | 340 | 12-23 | 320 | 867 |
| 250 | 330 | 319 | 355 | 400 | 12-28 | 370 | 1042 |
| 300 | 356 | 370 | 410 | 455 | 12-28 | 370 | 1297 |
| 350 | 381 | 429 | 470 | 520 | 12-29 | 450 | 1453 |
| 400 | 406 | 480 | 526 | 580 | 16-28 | 450 | 1692 |

| | PARTS | MATERIALS |
|----|-----------------|--------------------|
| 1 | Body | Ductile Iron |
| 2 | Resilient wedge | Ductile Iron +EPDM |
| 3 | Wedge | Ductile Iron |
| 4 | Stem | Stainless Steel |
| 5 | Gasket | EPDM |
| 6 | Bonnte | Ductile Iron |
| 7 | Bolts | Steel |
| 8 | O-Ring | EPDM |
| 9 | Gasket | PTFE |
| 10 | O-Ring | EPDM |
| 11 | O-Ring | EPDM |
| 12 | Yoke | Ductile Iron |
| 13 | Bolts | Steel |
| 14 | Nuts | Steel |
| 15 | Gasket | PTFE |
| 16 | Gasket | PTFE |
| 17 | Yoke Bushing | Brass |
| 18 | Handwheel | Ductile Iron |
| 19 | Plate | Aluminium |
| 20 | Handwheel Nut | Brass |