

F621

Semi-Lugged Lever Operated Butterfly Valves



F621

PN16

Features & Benefits

- WRAS approved for potable water applications -10°C to 80°C
- Robust, ductile iron valve body for long life service
- Valve body semi-lugged to fit PN16 or ANSI Class 125 flanges
- The anti-blow out stem design provides a safe and secure operation
- Integrated notch plate for a more compact design and aluminium lever to reduce risk of corrosion
- Fully bonded epoxy paint system for superior corrosion resistance
- Suitable for applications where Level 3 C3 (Medium) corrosion protection is required
- Suitable for use with flanges conforming to BS EN 1092-2 PN10 or PN16 and ANSI B16.1 Class 125
- Maintenance free valve design, reducing downtime
- Suitable for a wide temperature range -10°C to 100°C



GENERAL VALVES

Materials

PART	MATERIAL
Body	Ductile Iron ASTM A536 64-45-12 (Epoxy Paint)
Disc	Aluminium Bronze C954 ASTM B148
Liner	EPDM (WRAS Approved) Temp. -10 to 100°C (80°C WRAS)
Shaft	Stainless Steel Type 410
Taper Pin	Stainless Steel Type 410
O-Ring	Buna-N
Bushing	PTFE
Lever	Aluminium Alloy (Epoxy Paint)

Dimensions & Weights

SIZE (mm)	WEIGHT (kg)	A (mm)	A1 (mm)	B (mm)	C (mm)	D (mm)	E (mm)	F (mm)	G (mm)	Kv	FLANGE SLOTS TO SUIT
50	2.4	109	246	72	43	32	212.5	100	52.9	98	DN50 PN16 / 2" CL125
65	3.3	131.5	278.5	82	46	32	212.5	120	64.6	167	DN65 PN16 / 2.1/2" CL125
80	3.6	134	294	95	46	32	212.5	127	79	258	DN80 PN16 / 3" CL125
100	4.5	163	343	115	52	32	212.5	156	104.4	512	DN100 PN16 / 4" CL125
125	6.3	169	359	125	56	32	212.5	190	123.5	872	DN125 PN16 / 5" CL125
150	8.4	179	392	142	56	40	245	212	155.8	1,347	DN150 PN16 / 6" CL125
200	13.4	224	465	170	60	40	378	268	202.7	2,675	DN200 PN16 / 8" CL125

*Kv coefficient denotes valves in fully open position

Dimensional Drawing

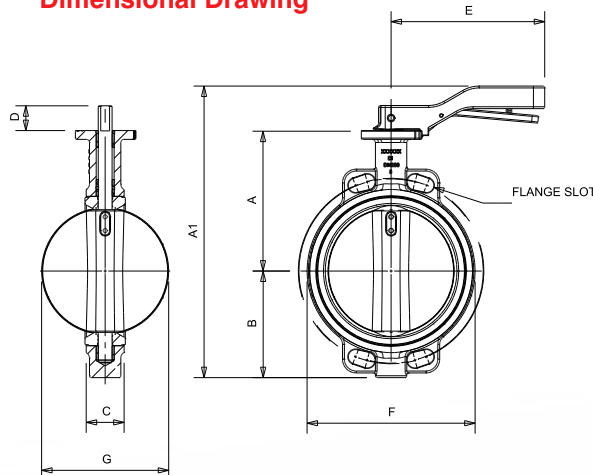

Pressure/Temperature Ratings

	F621
MAX TEMPERATURE (°C)	-10 to 100
PRESSURE (BAR)	16

Intermediate pressure ratings shall be determined by interpolation.

WRAS approved -10 to 80°C

PRESSURE RATING: PN16 / CLASS 125

TEST PRESSURES:

Shell: 24 Bar Seat: 17.6 Bar

SPECIFICATION: Lever operated epoxy coated Ductile Iron Body.

Semi-lugged. Aluminium disc. EPDM liner. To suit flange connections BS EN 1092-2 PN10 or PN16 and ANSI B16.1 Class 125. Valves may be used for flow regulation. Valve design conforms to BS EN 593. Face to face conforms to BS EN 558.

MEDIUM:

Suitable for Group 2 liquids as defined by the Pressure Equipment Directive 2014/68/EU* WRAS approved valves.

Valid as of 110620

Every effort has been made to ensure that the information contained in this publication is accurate at the time of publishing. Crane Ltd assumes no responsibility or liability for typographical errors or omissions or for any misinterpretation of the information within the publication and reserves the right to change without notice.