

Dual Plate Check Valve

FIG. DCV 083

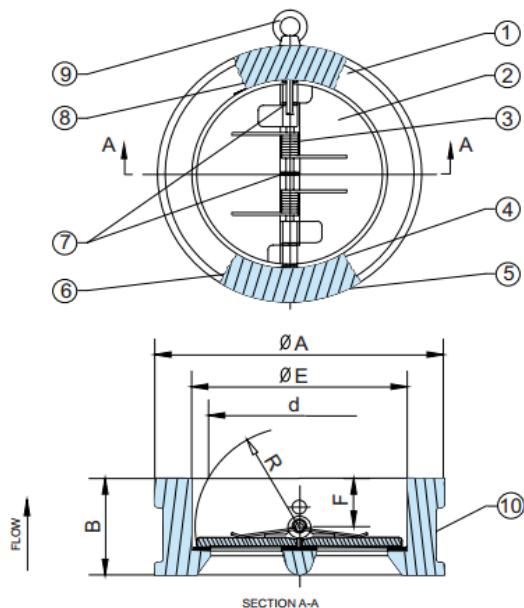

TECHNICAL DATA

WORKING PRESSURE	16bar	
TESTING PRESSURE	SHELL TEST	24bar
	SEALING TEST	17.6bar

DN	B	E	F	R	A	
					PN10	PN16
50	43	65	19	28.8	107	107
65	46	80	20	36.1	127	127
80	64	94	27	43.4	142	142
100	64	117	28	52.8	162	162
125	70	145	30	65.7	192	192
150	76	170	30	78.6	218	218
200	89	224	31	104.4	273	273
250	114	265	33	127	328	328
300	114	310	50	148.3	378	382
350	127	360	43	172.4	438	442
400	140	410	45	197.4	488	495

MATERIALS OF MAIN PARTS

	PARTS	MATERIALS
1	Body	Cast Iron
2	Plate	Stainless Steel 304
3	Spring	Stainless Steel 304
4	Hinge Pin	Stainless Steel 304
5	Plug	Carbon Steel
6	Body Bearing	Carbon Steel
7	Spring Bearing	PTFE
8	Stop Pin	Stainless Steel
9	Eye Bolt	Carbon Steel
10	Body Seat	EPDM