

Wafer Butterfly Valve DN40-DN200 PN10/PN16

FIG. DBL 104 - DBL 105

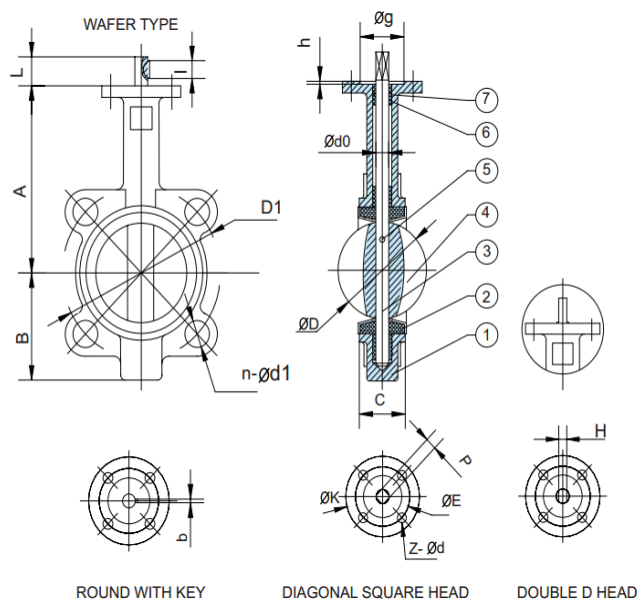

FACE TO FACE	BS5155, DIN3202, ISO5752
FLANGES	DIN, BS
WORKING PRESSURE	PN16 (200PSI)



MATERIALS OF MAIN PARTS

	PARTS	MATERIALS	
		DBL 104	DBL 105
1	Body	Ductile Iron	
2	Seat	EPDM	
3	Shaft	ANSI 410	
4	Disc	Ductile Iron + Ni	CF8
5	Pin	Stainless Steel	
6	Bushing	Ductile Iron	
7	O ring	EPDM	

DIMENSIONS

DN	A	B	C	L	d0	P	H	UPPER FLANGE					D1	n-ød	
								K	E	z-d	g	h		PN10	PN16
40	145	75	33	32	12.6	-	-	77	50	4-7	35	3	110	4-18	4-18
50	161	80	42	32	12.6	9	10	77	50	4-7	35	3	125	4-18	4-18
65	175	89	44.7	32	12.6	9	10	77	50	4-7	35	3	145	4-18	4-18
80	181	95	45.2	32	12.6	9	10	77	50	4-7	35	3	160	8-18	8-18
100	200	114	52.1	32	15.7	11	12	90	70	4-9	55	3	180	8-18	8-18
125	213	127	54.4	32	18.9	14	14	90	70	4-9	55	3	210	8-18	8-18
150	226	139	55.8	32	18.9	14	14	90	70	4-9	55	3	240	8-23	8-23
200	260	175	60.6	45	22.1	17	17	125	102	4-12	70	3.5	295	8-23	12-23